

Seat No. **OCT-NOV 2025 WINTER EXAMINATION****1154 B.Tech. CBCS****Sub. Name: Mechanical System Design****Sub. Code: 67502/83713/83948****Day and Date: Thursday ,18-12-2025****Total Marks: 70****Time: 02:30 PM To 05:00 PM**

- Instructions:**
1. All questions are compulsory
  2. Assume suitable data wherever necessary and mention it boldly
  3. Draw neat labelled diagrams wherever necessary
  4. Figures to the right indicate full marks
  5. Use of Scientific calculator is allowed

**Q1) A.** Explain following w.r.to aesthetic design **[5]**  
 i) Form ii) Symmetry and Balance iii) Colour iv) Style

**B.** Ergonomic considerations in design of displays and controls. **[6]**

**OR**

Explain with suitable example adequate design and optimum design

**Q2) A.** Explain with neat sketches types of end closures of pressure vessel. **[5]**

**OR**

Explain with neat sketches types of pressure vessel support.

**B.** A high-pressure cylinder consists of a steel tube with inner and outer diameters of 30 mm and 50 mm respectively. It is jacketed by an outer steel tube, having an outer diameter of 70 mm. The tubes are assembled by shrinking process in such a way that maximum principal stress induced in any tube is limited to 110 N/mm<sup>2</sup>. Calculate the interference pressure and original dimensions of tubes. The modulus of elasticity of the steel used for tubes is 207000 N/mm<sup>2</sup>. **[8]**

**Q3) A.** Explain Thermal consideration and rating of brakes. **[4]**

**B.** An automotive type internal expanding brake (double-shoe) is as shown in Fig. 3.b. The face width of the friction lining is 40 mm and the maximum intensity of pressure is limited to 1 N/mm<sup>2</sup>. The coefficient of friction is 0.32. The angle  $\theta_1$  can be assumed to be zero, calculate:  
 i) The actuating force P, and  
 ii) The torque-absorbing capacity of the brake **[7]**

**OR**

A centrifugal clutch consists of four shoes, each having a mass of 1.5 kg. In the engaged position, the radius to the center of gravity of each shoe is 110 mm, while the inner radius of the drum is 140 mm. The coefficient of friction is 0.3. The pre-load in the spring is adjusted in such a way that the spring force at the beginning of engagement is 700 N. the running speed is 1440 rpm. Calculate

- i. The speed at the engagement begins
- ii. The power transmitted by the clutch at 1440 rpm

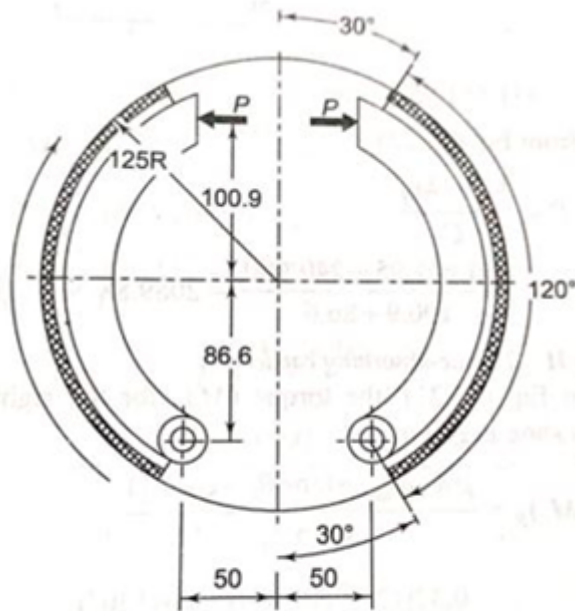

Fig. 3.b.

**Q4) A.** What are considerations in design of multi-speed gear boxes? Explain. [4]

**OR**

Discuss the need of multispeed gearbox in machine tool.

**B.** A multi speed gear box is to be designed for a small size, general purpose machine tool for spindle speed varying between 200 rpm and 2000 rpm. If the recommended geometric progression ratio is as per R5 series: [9]

(i) Draw the candidate structure diagram for a machine tool gear box

(ii) Select the optimum structure diagram

**Q5) A.** Explain briefly stresses in cylinder wall. [5]

**B.** Determine the small and the big end bearings of the connecting rod for a diesel engine with the following data: [6]

Cylinder Bore = 100 mm

Maximum gas pressure = 2.45 MPa

(l/d) ratio for piston pin bearings = 1.5

(l/d) ratio for crank pin bearing = 1.4

Allowable bearing pressure for piston pin bearing = 15 MPa

Allowable bearing pressure for crank pin bearing = 10 MPa

**OR**

The cylinder of a four-stroke diesel engine has the following specifications:

Brake power = 5 Kw

Speed = 600 rpm

Indicated mean effective pressure = 0.5 MPa

Make a suitable assumption and calculate:

i. Bore and length of the cylinder liner

ii. Thickness of the cylinder liner

**Q6) A.** Guidelines during selection of Material Handling System (MHS). [5]

**OR**

Explain briefly Conveyors and its types.

- B.** An inclined belt conveyor is used for loading the mineral ore in a ship. The belt inclination is  $20^\circ$  for which the flow ability factor 'k' is  $2.5 \times 10^{-4}$ . the belt width is 1000 mm while belt speed is 2.0 m/s. if the specific weight of the mineral ore is  $16000 \text{ N/m}^3$ , determine the capacity of conveyor. **[6]**

## **End Of Question Paper**

**Important Note for Chief Exam Officer / SRPD Coordinator / Sr Supervisor/ Student -**

This Question Paper may be distributed for following Subjects as common code.

सदरची प्रश्नपत्रिका खालील विषयांकरिता वितरित करता येईल.

- 1] (101) Bachelor of Engineering (83948) Mechanical System Design Part 4 SEM 7
- 2] (101) Bachelor of Engineering (67502) Mechanical System Design Part 4 SEM 7
- 3] (1154) B.Tech. CBCS (83713) Mechanical System Design Part 4 SEM 7