

| | |
|------------|--|
| Seat No | |
|------------|--|

F.Y.B.Tech. (Semester – I and II) (CBCS)

Examination, June– 2025

Applied Mechanics

Sub. Code : 71819

Day and Date : Wednesday, 18/06/2025

Total Marks :70

Time : 10.30 a.m. to 1.00 p.m.

- Instructions :
- 1) Solve any THREE questions from each section.
 - 2) Figures to the right indicate full marks.
 - 3) Assume suitable data if necessary and state them clearly.
 - 4) Answers shall be supported by adequate sketches
 - 5) Use of non programmable, scientific calculator is allowed.

SECTION-I

- Q.1) a) Define the term, force and explain the characteristics of force. (4)
- b) Three forces $2P$, $3P$ and $4P$ act along the sides of an equilateral triangle of side 100 mm taken in order. Find the magnitude and position of the resultant force. (8)

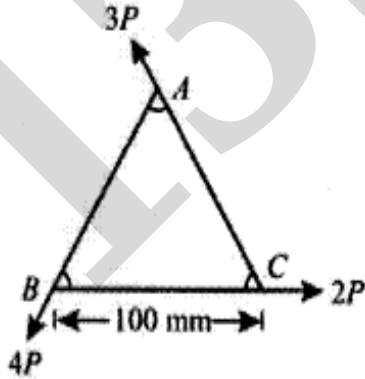

- Q.2) a) State and explain the term FBD. (4)
- b) Two identical rollers, each weighing 100 N , are supported by an incline and vertical wall as shown in figure. Calculate the support reactions at the points of contact A, B and C. (8)

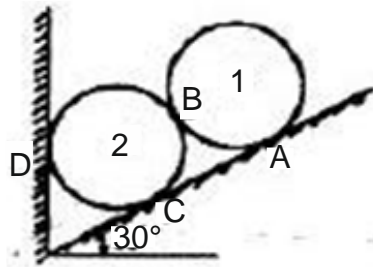

- Q.3) a) Explain various types of supports to the beam. (3)
 b) Determine the support reactions of the beam loaded and supported as shown in figure. (8)

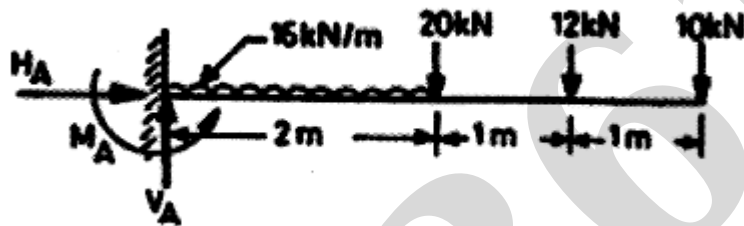

- Q.4) a) State and explain Parallel axis theorem. (3)
 b) Find the moment of inertia of angle section as shown in figure along its centroidal XX and YY axis. (8)

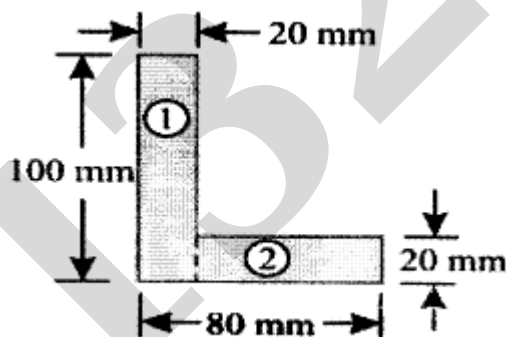

SECTION II

- Q.5) a) a) State and explain De Alembert's principle. (3)
 b) A pump lifts 40 m^3 of water to a height of 50 m and delivers it with a velocity of 5 m/s. What is the amount of energy spent during the process? If the job is done in half an hour, what is the input power of the pump which has an overall efficiency of 70%. (8)

- Q.6)** a) Explain in brief, Kinetics and Kinematics. (3)
- b) A glass marble whose weight is 0.2 N, falls from a height of 10 m and rebounds to a height of 8 m . Find the impulse and the average force between the marble and the floor, if the time during which they are in contact is $1/10^{\text{th}}$ of a second. (9)
- Q.7)** a) State Newton's law of circular motion. (3)
- b) Find at what speed a vehicle can move round a curve of 40 m radius without sideslip: (9)
- (i) On level road
- (ii) On a road banked to an inclination of 1 in 10.
- At what speed can the vehicle travel on a banked road without any lateral frictional force?
- (Assume coefficient of friction between tyre and the road as 0.4)
- Q.8)** a) State and explain Law of conservation of Momentum? (3)
- b) A 80 N body moving to right at a speed of 3 m/s strikes a 10 N body that is moving to the left at a speed of 10 m/s. The final velocity of 10 N body is 4 m/s to the right. Calculate the coefficient of restitution and the final velocity of the 80 N body. (8)
-